

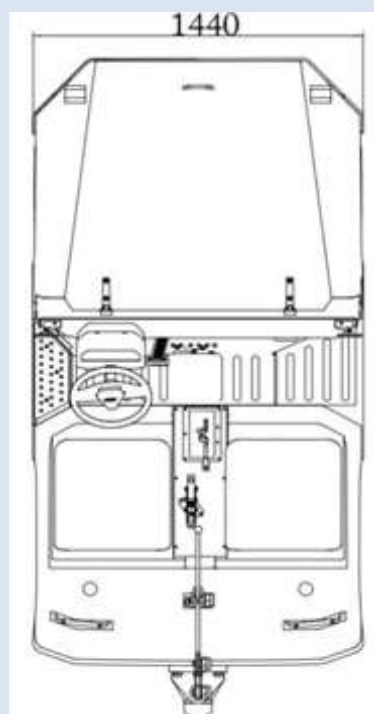

Basic

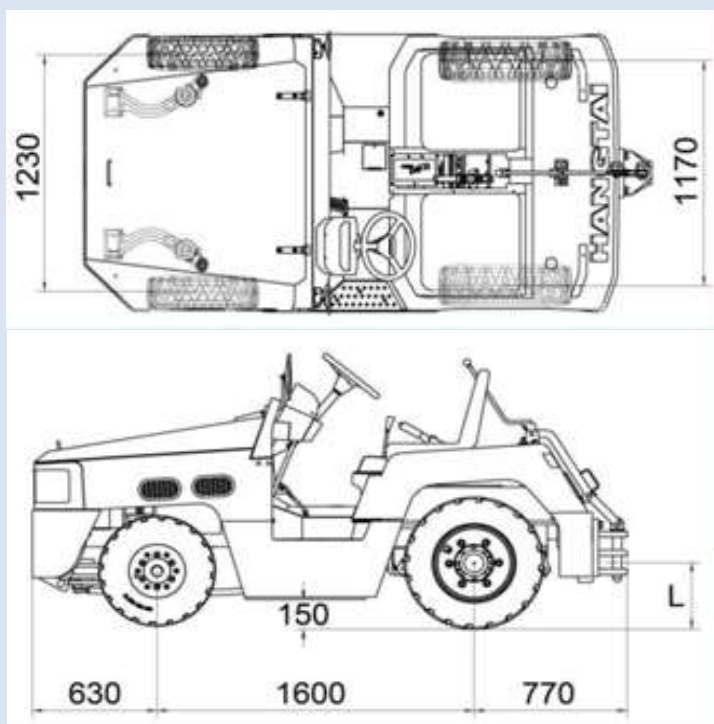

With Overhead Guard



### Optional configuration

Windshield, simple driving cab and sealed cab, air conditioning, hot air blower; custom-built traction pins, small loading platform, monitoring and recording system and so on.



With Cabin



配货斗

主要技术参数表 Main technical parameters table

Model		型号	TD35	
性能 Performance	最大牵引力 Max. drawbar pull	KN	35	
	最大牵引重量 (干燥的混凝土地面) Max. towed weight	单车 With one trailer Kg	44000	
	最大行驶速度 Max. travel speed	前进 Forward	Km/h	25
		后退 Backward	Km/h	13
	最小转弯直径 Min. turning radius	mm	6000	
空载爬坡能力 Max. gradeability with no load	%	35		
重量 Weight	整机重量 Truck weight(no load)	Kg	5100	
尺寸 Dimensions	外形尺寸 Outline dimension	总长 Overall length	mm	3180(含牵引栓 with towing bar)
		总宽 Overall width	mm	1440
		总高 Overall height	mm	1450
	轴距 Wheelbase	mm	1605	
	轮距 Wheelbase	前轮 Front	mm	1250
		后轮 Rear	mm	1160
	前悬出 Front overhang	mm	665	
	后悬出 Rear overhang	mm	910	
	牵引栓高度 Towing bar height	mm	304.8/450	
最小离地间隙 Min. ground clearance	mm	150		
发动机 Engine	型号 Model		MITSUBISHI S4S-DT	
	额定功率 Rated output	KW/rpm	62/2500	
	最大扭矩 Max. torque	N.m/rpm	265/1800	
变速箱 Transmission	型号 Model		Graziano PST2	
	变速方式 Gearshift method		自动 Automatic	
驱动桥 Drive Bridge			JCB FGM0249	
轮胎 Tire	前轮 Front		6.50-10-10PR	
	后轮 Rear		7.50-15-12PR	
制动 Brake	行车制动 Service brake		液压 Hydraulic	
	驻车制动 Parking brake		机械 Mechanical	

Outline size picture

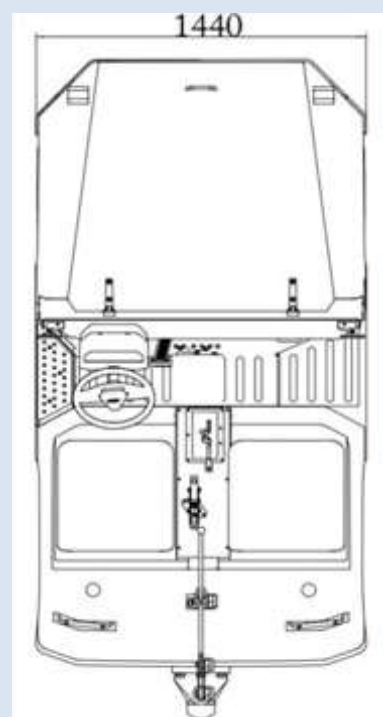
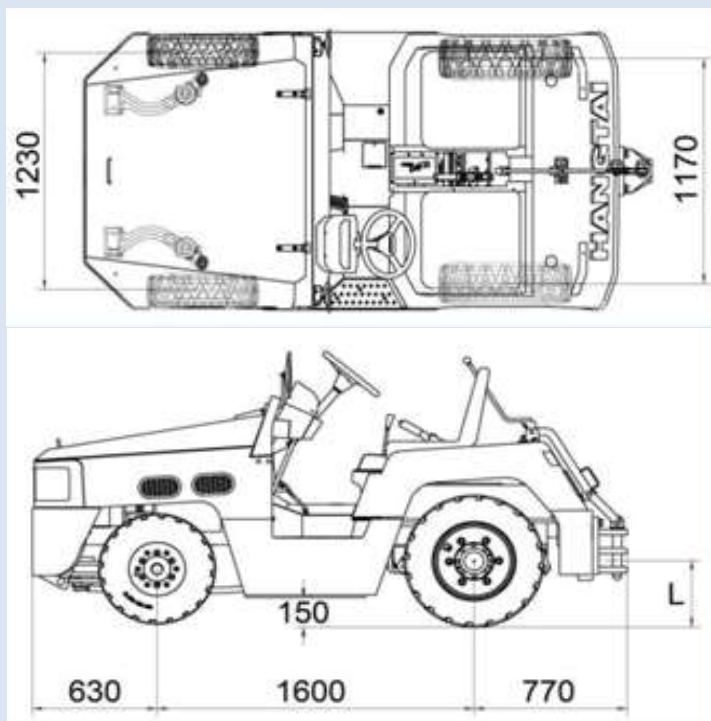



**AIRPORT EQUIPMENT SERVICES PTE. LTD.**

41 Kallang Pudding Road, #03-10 Golden Wheel Building,  
Singapore 349316 Phone: (65) 65421160 Fax: (65) 65421160  
Email: aessg@singnet.com.sg Website: www.aessg.com

---

(Business Registration No: 199400661M)

Mitsubishi S4S-DT Engine



Graziano PST2 Transmission



JCB FGM0249 Drive Bridge

