

(Business Registration No: 199400661M)



Building Quality Ground Support Products Since 1961

- 8" x 15' high strength aluminum tube
 - Fully retractable hydraulic running gear for adjustable height
 - Safety lock system to avoid separation from aircraft
 - Durable powder coat paint
 - Quality shear bolts for aircraft protection
 - Extra set of shear bolts included
 - Pneumatic tires
- Options:
- Foam filled tires
 - Shock mounted lunette
 - Spliced tube for easy transport

15F2284

A318 A319 A320 A321 Towbar

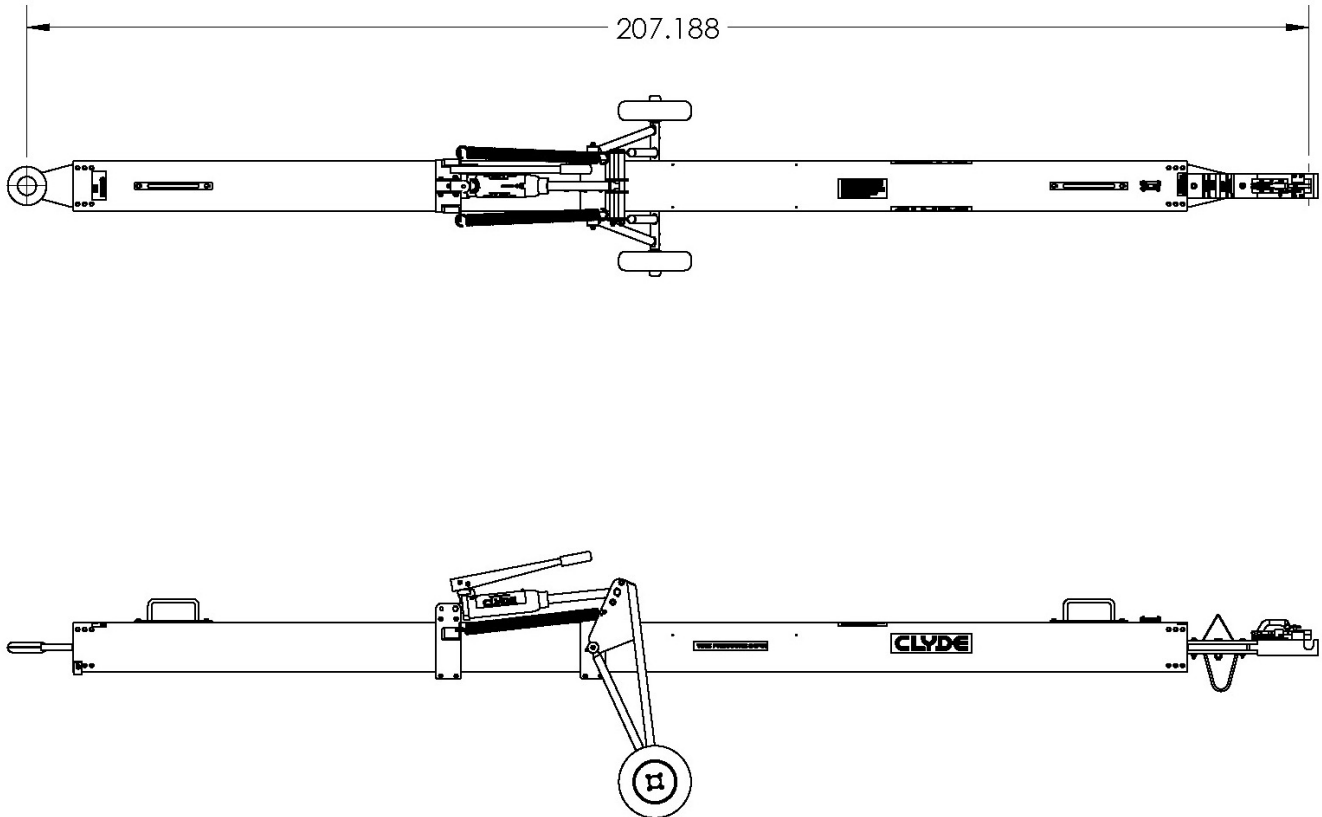

Shipping Information

Shipping Weight

- 350 lbs.

Crated Weight

- 730 lbs.

Shipping Dimensions

- Length — 212"
- Width — 29"
- Height — 25"

Crated Dimensions

- Length— 217"
- Width— 26"
- Height— 27"



Building Quality Ground Support Products Since 1961

- 8" x 15' high strength aluminum tube
- Safety lock system to avoid separation from aircraft
- Fully retractable hydraulic running gear for adjustable height
- Durable powder coated paint
- Quality shear bolts for aircraft protection
- Extra set of shear bolts included
- Pneumatic tires
- Options:
 - Foam filled tires
 - Shock mounted lunette

15F2916

737 / 100-900 Towbar

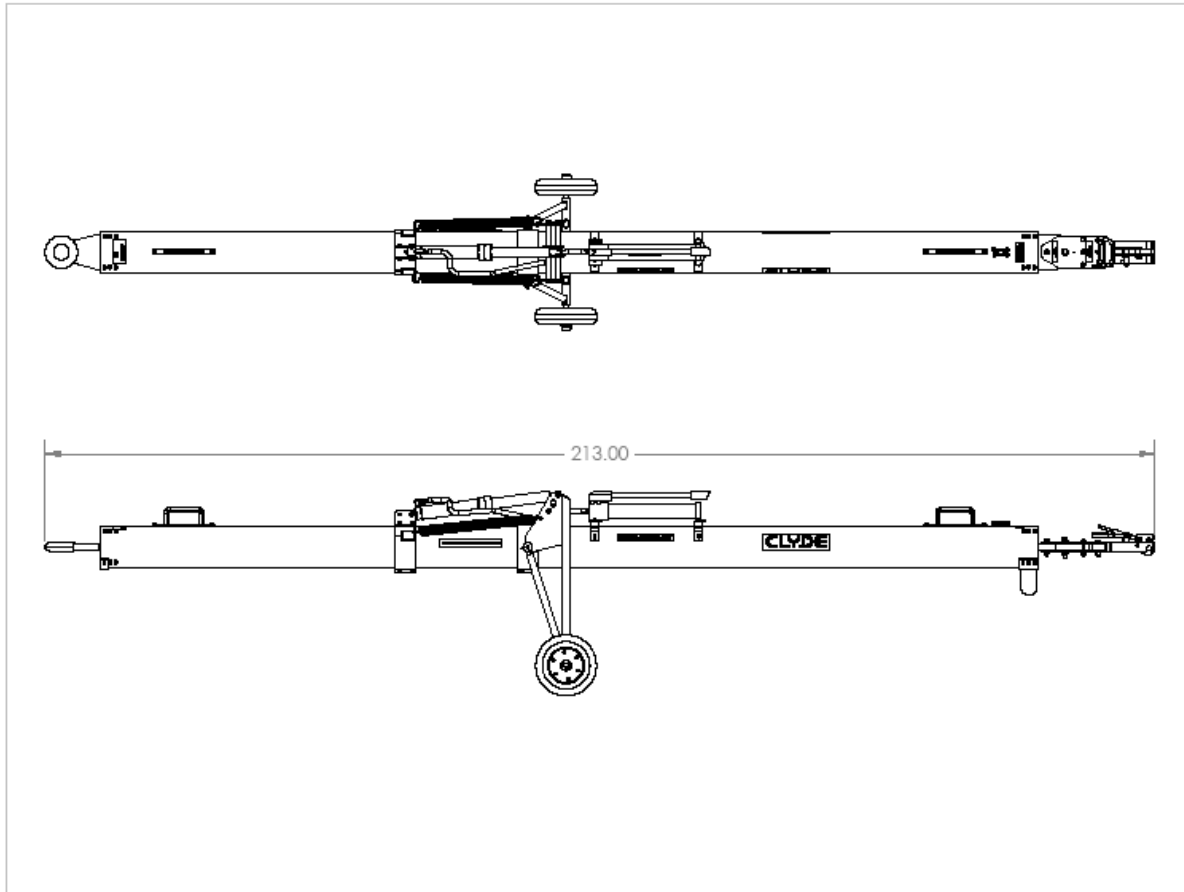

Shipping Information

- Shipping weight:
 - 325 lbs.
- Shipping dimensions:
 - Length - 205"
 - Width - 25"
 - Height - 25"
- Crated weight:
 - 730 lbs.
- Crated dimensions:
 - Length - 217"
 - Width - 26"
 - Height - 27"